



## 1993 MARYLAND STATE FFA CONVENTION

The 65th Annual Maryland State FFA Convention was held on June 22 and 23, 1993 at the Ramada Inn in Hagerstown, Maryland. Over two-hundred and eighty (280) FFA members and guests participated in convention activities including delegate sessions, committee meetings, leadership contests, and chapter competitions. The convention activities were directed by the 1992-93 State FFA Officer Team under the leadership of President Becky Mills from the Frederick FFA Chapter. [See Convention Program for listings of 1992-93 State Officer Team as well as activities, award winners and honorees.

Special activities of the Convention included presentations by National Vice-President, Mr. John Kleiboeker. Other activities included a Record Book Awards Program sponsored by Maryland Farm Bureau and the American Royal Ambassador Scholarship Program sponsored by Farm Credit Bank of Baltimore. Recognition of individual FFA members included State Agriculturist Degree recipients, State Proficiency Award Winners and American FFA Degree Candidates, as well as Honorary State Agriculturist Degree Recipients. Recognition of Maryland FFA Chapters included 1993 Superior Chapter Awards, National Chapter Awards, Building Our American Communities (BOAC) Area and State Award, Governor's BOAC Citation, and the National FFA Safety Awards.

Two special VIP awards were presented to recognize outstanding con-

tributions to the Maryland FFA Association. The Blue and Gold Award was given during the Banquet Session to Mr. Gene L. Swackhamer, President of the Farm Credit Bank of Baltimore. The Distinguished Service Award was also presented during the Banquet session to the Maryland Agricultural Education Foundation, Inc. The award was accepted by Mr. Richard Price, President of the Foundation.

The Maryland FFA Foundation, Inc. gave special recognition to the Sponsors of FFA Activities during the third convention session. According to Dr. Boyd Robinson, Jr., Chairman of the Foundation Board of Trustees, "the FFA Foundation had a banner year in solicitations for support of Maryland FFA Activities". During the session twenty-seven contest sponsors were recognized and the outstanding sponsor was presented to the Central Maryland Antique Tractor Club. Dr. Robinson further noted that "the generosity of Maryland's agricultural industry and agricultural organizations in providing financial support for the sponsorship of the various FFA contests is genuinely appreciated by FFA members across the State."

The American Royal Ambassador Program is a scholarship program that includes both male and female contestants. These individuals were interviewed on Wednesday morning and winners were announced during the American Royal Ambassador Dance that evening. This year's American Royal Ambassador Candidates who will represent Maryland in Kansas City,

MO. in the American Royal Ambassador Contest are Miss Christine Masser of the Clear Spring FFA Chapter and Mr. Mike Kuster of the Frederick FFA Chapter.

As State winners they will each receive a Five-Hundred Dollar Scholarship from the Farm Credit Bank of Baltimore.

Candidates for the 1993-94 State FFA Officer Team were interviewed on Saturday, June 12 1993. These individuals were approved by vote of the delegate body and installed during the Awards banquet by the outgoing team.

Members of the 1993-94 State FFA Officer Team are:

Secretary—Ms. Stephanie M. Maines,  
Harford Tech. FFA

President—Ms. Freedom Joy Titus,  
Frederick FFA

Vice-President—Ms. Trish E.  
Marsh, Oakland FFA

Sentinel—Ms. Mandy Henderson,  
Queen Annes FFA

Treasurer—Mr. Mark Spurrier,  
Linganore FFA

Chaplain—Ms. Heather C. Leppo,  
Catoclin FFA

Reporter—Ms. Monica Harshman,  
Linganore FFA

### Inside This Issue

Executive Director Writes .....	2
Local Youth National Finalist ....	3
Spring Conference Pictorial .....	4
"Year-at-a-Glance" .....	4
"Teacher-of-the-Year" .....	6
MVA Membership Application ....	7

From the 

## Executive Director's Chair

Dr. Brian K. McAlister

Welcome back to another school year! It is hard to believe that it was just over a year ago that I introduced myself as your new Executive Director and welcomed in a new era for MVA. I approach this column with both optimism and reluctance. Let's start with the positive.

I am delighted to announce that **Conference '93** is upon us once more. The conference planning committee has been hard at work preparing this year's conference **Visions of Opportunity: Connections that Work**. It will be held **October 22, 1993** at **Martin's West** in Baltimore. Our **keynote speaker** at this year's luncheon will be **The Honorable Kurt L. Smoke, Mayor of Baltimore**. Register today!

I am also proud to announce that we have selected March 12, 1994 as a tentative date for our Spring conference. We realize that the low attendance last year may have resulted from not securing and advertising the conference date early enough. So please mark this date on your calendar and plan to come to our spring conference next March.

In other noteworthy news, you should be aware that our membership is declining. First, we must realize that membership is somewhat cyclical. We have fluctuated from approximately 400 active members (May, 93) to 354 active members (August, 93). A better comparison might be the 354 members as of August, 1993 to the 381 active members reported October, 1992. This reflects a decrease of 27 members (roughly a 7% drop). I think one of the meaningful observations is

that Divisions that have active representation on the board tended to either hold their memberships steady, or have shown drastic increases, whereas those divisions that are not active on the board have seen their MVA membership drop. I would especially like to congratulate MACE who has increased its MVA membership from 26 to 31 and MAVESNP who has increased its MVA membership from 46 to 56.

Membership is very important to any organization. Let's face it, **our membership is our Association** and MVA can be anything its membership wants it to be. But in order for MVA to serve its members there must be some organized way of doing business. In our case it is the executive board which is made up of elected officers and representatives from each of the divisions. What troubles me is that many of our divisions have no board representation. In addition, there are other divisions that have named representatives that rarely, if ever, attend board meetings. This is not meant to be a slam to any one person or division, but a plea to our divisions to provide its membership with representation. It is the right of your members to have representation on the board. And if you do not, you are not providing your membership with something to which they are entitled by joining your division of MVA.

I would like to remind the membership that they are welcome to attend our board meetings. They are usually held the first Friday of each month in the J.M. Patter-

son Building on the campus of the University of Maryland at College Park. A list of the meeting dates is published in this newsletter.

Now for my last bit of news. This past year has been filled with uncertainty for me personally and professionally. As many of you may or may not know, we are in the final phase-out of the Industrial, Technological and Occupational Education department (EDIT) at the University of Maryland. There will be no more EDIT classes offered after the Spring of 1994. This has put me in an awkward position professionally. I have been officially placed in the department of Curriculum and Instruction. It has been made clear, that as a nontenured faculty member, my best chance of survival on this campus would be to refocus my efforts in my new department. The other alternative is to seek employment elsewhere. You can imagine the dilemmas I now face. Regardless of my ultimate personal decision regarding my career, I decided to inform the executive board at our September meeting to start looking for a new executive director. I plan to step down as soon as a replacement is found. This was a very hard decision for me to make and I wish I had never been placed in this situation. But after closely scrutinizing my alternatives, I believe I am doing what is best for me and my family's future, and MVA.

I have enjoyed working as your executive director. It was a valuable experience. I especially appreciate all of the support I have received from the executive board over the past year. And remember, I am not gone yet. Unless something else happens, I plan to continue as your executive director until a replacement is found.

**Have a great School Year!! I'll see you at Conference '93!!!!** 

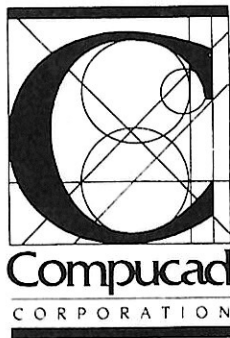

6707 Whitestone Road  
Suite One-O-One  
Baltimore, MD 21207  
301 944-6767

David B. Donaldson  
Vice President

### MVA BOARD

President .....	JOAN KEENAN
President-elect .....	(Open)
Past-President .....	KEN SMITH
Secretary, MMEA .....	CANDY ZENTZ
Treasurer .....	TOM HAWTHORNE
MCVA .....	DAVID MILLER
MATA .....	CARROLL SHRY JR.
MBEA .....	(Open)
MACE .....	DOLORES BROWN
HOE .....	(Open)
HEAM .....	CHERYL JONES
MAVESNP .....	IRIS HALL-WILLEY
MATTIE .....	JOHN HUBER
NRS .....	(Open)
NAABAVE .....	WILLIAM A. HAYES
MSDE/DCTE-Legislative .....	ED ROEBUCK
Awards Chair .....	BOB SPENCE

## Local Youth Named National Finalist

Robert Dinsmore, of Jefferson and a member of the Brunswick FFA chapter has been named a national finalist in competition for the National FFA Sheep Production Proficiency Award. (He/she) is now eligible to compete for national honors in the Sheep production proficiency award program at the National FFA Convention in Kansas City, MO, Nov. 10-12.

Robert became eligible for the award when (he/she) won the \$100 state FFA Sheep Production award. The award is one of 29 proficiency awards presented annually at local, state, and national levels to recognize FFA members for achievements in activities leading to careers in agriculture. Dinsmore will receive a plaque, a check for \$250 and partially paid travel expenses to the national FFA Convention, where (he/she) will compete against three other Sheep Production

national finalists.

This award is sponsored by **American Sheep Industry Association and Kent Feeds, Inc.** as a special project of the National FFA Foundation, Inc.

FFA is a national organization of 416,529 members preparing for leadership and careers in the science, business and technology of agriculture. The organization has 7,545 local chapters located throughout the United States, Puerto Rico, Guam and the Virgin Islands. FFA's mission is to make a positive difference in the lives of students by developing their potential for premier leadership, personal growth and career success. Local, state and national activities and award programs provide opportunities for students to apply knowledge and skills acquired through agricultural education. **c**

Please submit articles for *The Current News* letter to:

Dr. Brian K. McAllister  
Executive Director  
3216 J.M. Patterson  
Building  
Univ. of Maryland  
College Park, MD  
20742-2211

Deadline for  
Winter Issue  
November 30, 1993



Goodheart-Willcox

123 W. Taft Drive • South Holland, IL 60473-2089  
Phone 1-708-333-7200  
Fax 1-708-333-9130

JOHN F. FLANAGEN  
PRESIDENT

KATIE McMILLIAN  
AD. DIRECTOR

des

### DIVERSIFIED EDUCATIONAL SYSTEMS, INC.

P.O. Box 388  
Berryville, Virginia 22611

Providing laboratory design and state of the art educational training equipment for over 25 years.

To implement:

Vocational &  
Technology  
Educational Programs

Please call collect  
(703) 955-2782

Robert E. Wyatt  
Maren Johnson

education and  
industry  
working together

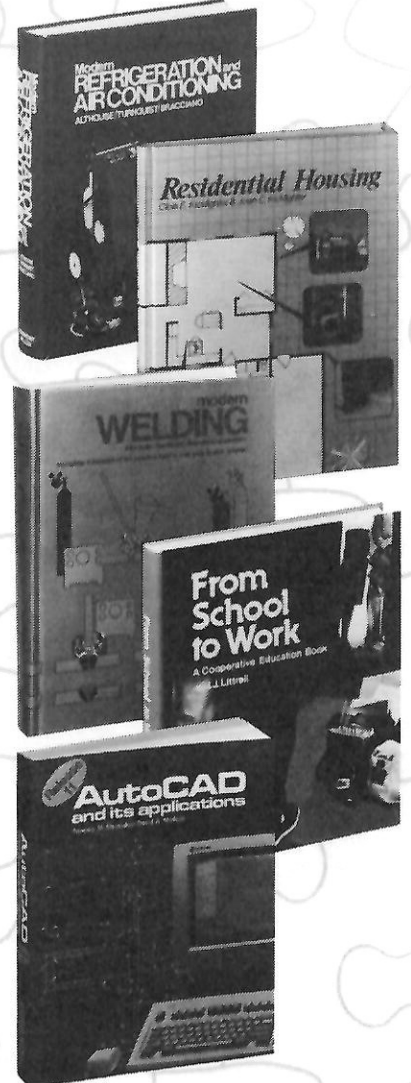

- MODERN REFRIGERATION AND AIR CONDITIONING . . . \$27.75
- RESIDENTIAL HOUSING \$24.45
- MODERN WELDING . . . \$23.85
- FROM SCHOOL TO WORK . . . . . \$21.75
- AUTOCAD and its Applications Release 11 . . . . . \$25.50

Check the books you wish to order on 30-day approval. Clip this ad and mail with your name and address to:

GOODHEART-  
WILLCOX  
**G-W** WILLCOX CO., INC.

123 W. Taft Drive  
South Holland, Illinois 60473-2089

Call Toll Free 1-800-323-0440

# SPRING CO

## Howard County S

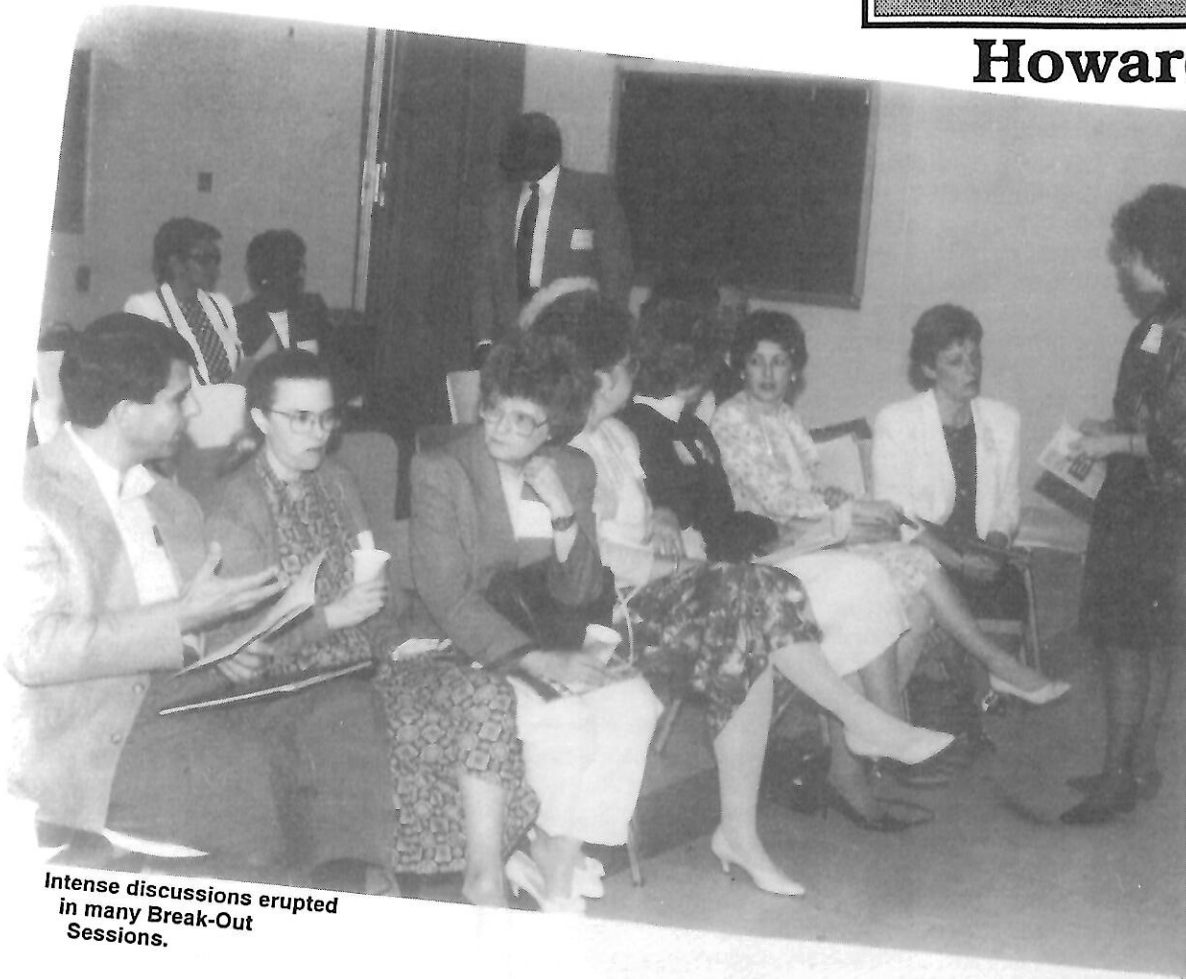

Intense discussions erupted in many Break-Out Sessions.



MVA Executive Director Brian McAlister presents an award during the luncheon.

### MARYLAND VOCATIONAL ASSOC MEETING DATES

#### "A-YEAR-AT-A-GLAN

(All Board Meetings at the  
University of Maryland, College Park  
J.M. PATTERSON BUILDING

FRIDAYS 5:00 TO 7:00 PM

# CONFERENCE

## ool of Technology



Mr. Jeff Goldstein, Keynote Speaker, at the Spring Conference, makes another point about the value of Technologists and Scientists working together.

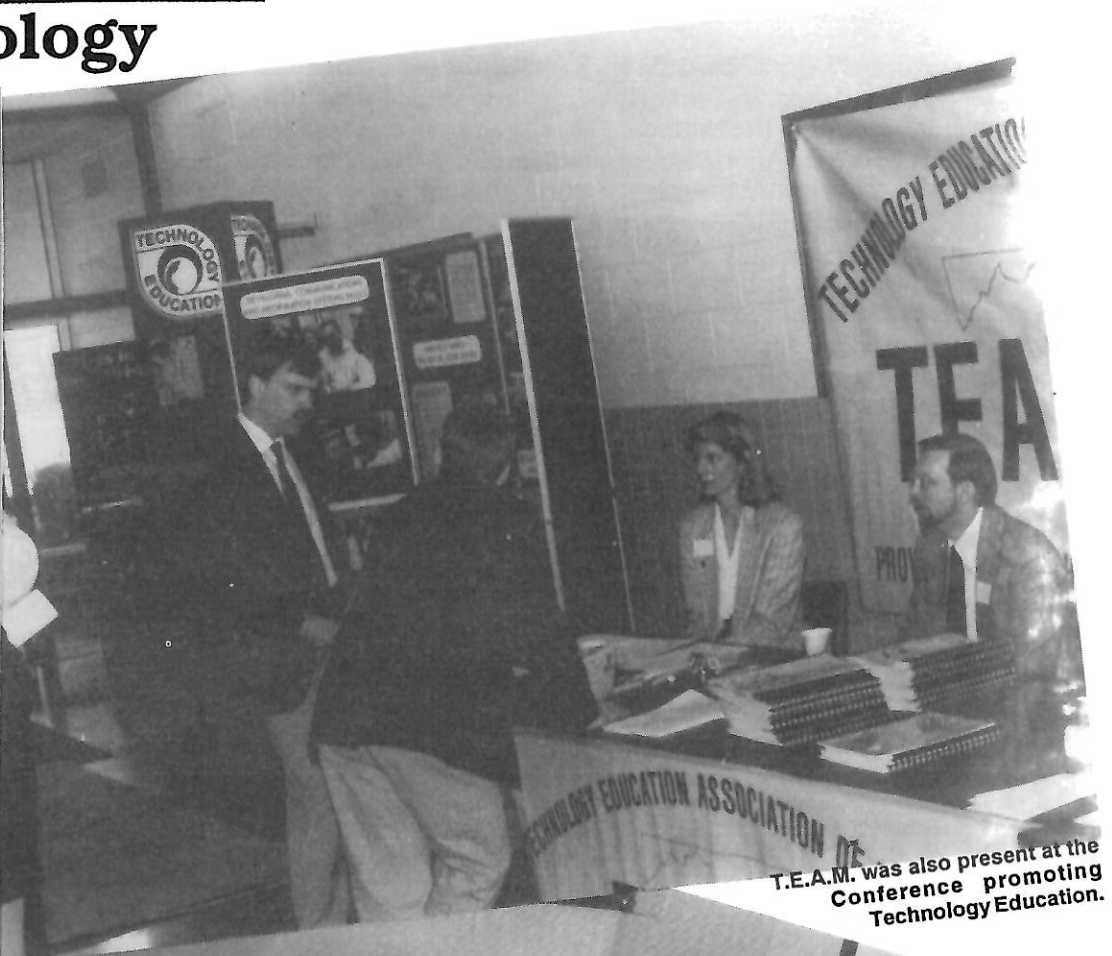

T.E.A.M. was also present at the Conference promoting Technology Education.

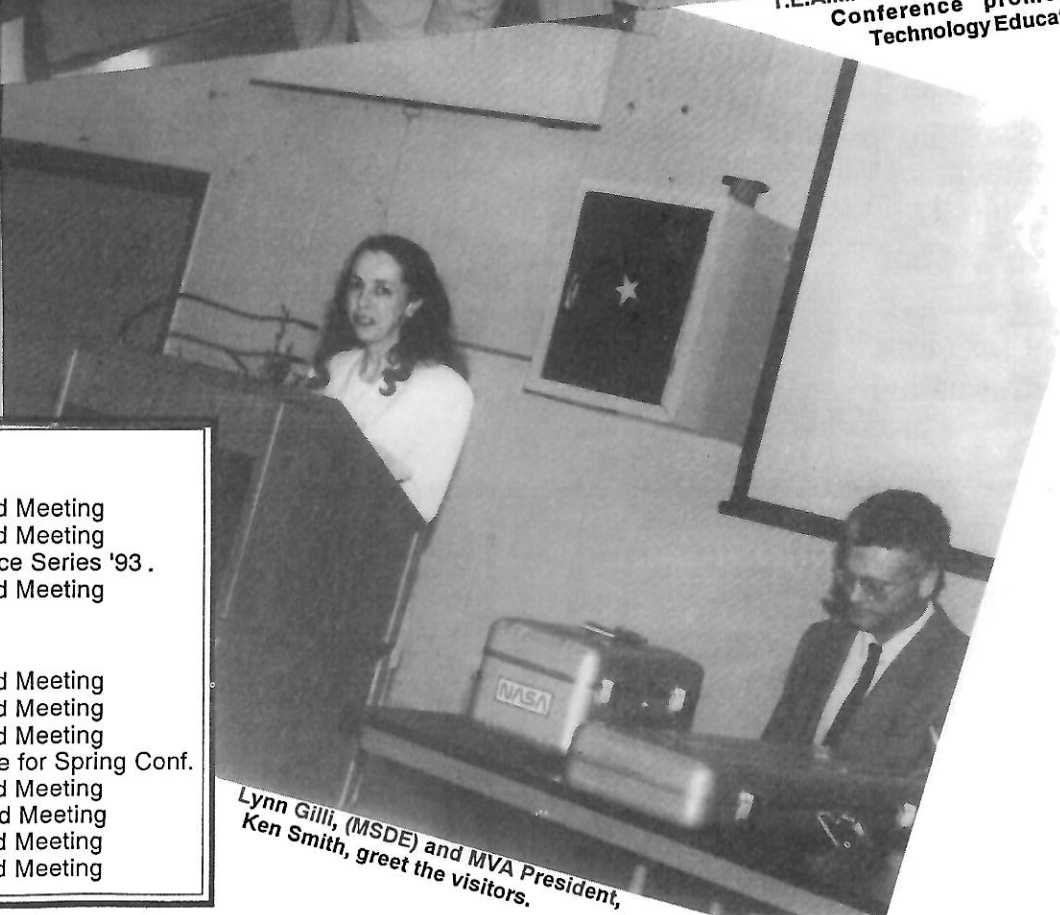

Lynn Gilli, (MSDE) and MVA President, Ken Smith, greet the visitors.

### 1993

- September 10 - Full Board Meeting
- October 1 - Full Board Meeting
- October 22 - Conference Series '93.
- November 5 - Full Board Meeting
- December 2-7 - AVA

### 1994

- January 7 - Full Board Meeting
- February 4 - Full Board Meeting
- March 4 - Full Board Meeting
- March 12 - Tent. Date for Spring Conf.
- April TBA - Full Board Meeting
- May 6 - Full Board Meeting
- June 3 - Full Board Meeting
- August 5 - Full Board Meeting

# Hering Selected 1993 Maryland Agriscience Teacher of the Year

Washington, D.C. - **Douglas Hering**, of **Buckeystown**, was named Maryland state winner in the National FFA Organization's Agriscience Teacher-of-the-Year award program. Hering, a high school agriculture instructor and FFA advisor of the Frederick FFA Chapter, is being honored for his/her excellence in teaching and providing practical applications of scientific principles and emerging technologies in agriculture.

As the Maryland Agriscience Teacher of the Year, Hering is eligible to compete for national recognition. Four national finalists will be picked in August and will each receive a \$1,500 school grant for the purchase of scientific equipment. The four finalists will travel to the 66th National FFA Convention, in Kansas City, MO, November 11-13, 1993, to compete for the title of the 1992 Agriscience Teacher of the Year award.

The award recognizes outstanding agricultural educators and FFA advisors who emphasize agriscience technology in their curriculum through innovative programs in food, environmental, animal, plant, soil and mechanical engineering sciences. The award program is co-sponsored by the Ford Motor Company Fund and PCS Sales as a special project of the National FFA Foundation, Inc.

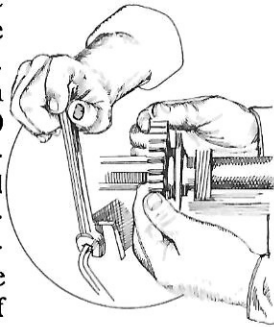

FFA is a national organization of 416,529 members preparing for leadership and careers in the science, business and technology of agriculture. The organization has 7,545 local chapters located throughout the United States, Puerto Rico, Guam and the Virgin Islands. FFA's mission is to make a positive difference in the lives of students by developing their potential for premier leadership, personal growth and career success. Local, state and national activities and award programs provide opportunities for students to apply knowledge and skills acquired through agricultural education.



**HEARLIHY & CO.**

**Modular Technology Education**  
*The Teaching System of the 21st Century*

714 W. Columbia Street, Springfield, Ohio 45504  
All 50 States 1-800-622-1000  
Canada (513) 324-5721  
FAX (513) 324-2260

**RICK ROGERS**

*Manager*  
**Marketing Group**

## Books for your training needs

American Tech offers texts and workbooks for a variety of technical areas. Call **1-800-323-3471** to request our full catalog or for more information.

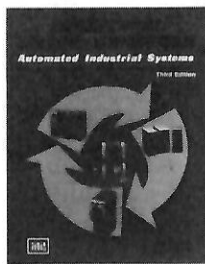

**BUILDING TRADES PRINTREADING - PART 1**  
By E. W. Sundberg,  
Thomas E. Proctor  
Text \$17.22



**PRINTREADING FOR WELDERS**  
By Thomas E. Proctor,  
J. F. Gosse  
Text \$15.72

**ELECTRICAL MOTOR CONTROLS**  
By G. Mazur,  
G. Rockis  
Text \$26.97



**HVAC Heating, Ventilating, and Air Conditioning**  
By S. D. Swenson  
Text \$18.72

**CARPENTRY**  
By L. Koel  
Text \$25.47

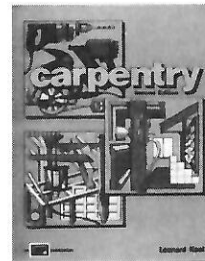

**NATIONAL ELECTRICAL CODE® BLUEPRINT READING Based on the 1993 NEC®**  
By James G. Stallcup  
Text \$17.97



**WELDING SKILLS**  
By J. W. Giachino,  
W. R. Weeks  
Text \$19.47



**METALLURGY**  
By B. J. Moniz  
Text \$26.22



**american technical publishers, inc.**  
1155 West 175th Street  
Homewood, IL 60430  
**1-800-323-3471 • Fax 1-708-957-1137**

We accept



School Prices Shown

## MVA MEMBERSHIP APPLICATION

Please this form to:

**Brian K. McAlister, MVA Exec. Dir.**  
**3216 J.M. Patterson Building**  
**University of Maryland**  
**College Park, MD 20742**

Date: \_\_\_\_\_  
 Name: \_\_\_\_\_ Social Security # \_\_\_\_\_  
 Address: \_\_\_\_\_  
 City: \_\_\_\_\_ State: \_\_\_\_\_ Zip: \_\_\_\_\_  
 Home Phone: \_\_\_\_\_ Daytime Phone: \_\_\_\_\_  
 The County Where You Work: \_\_\_\_\_ Zip: \_\_\_\_\_

### MVA MEMBERSHIP (Check method of affiliation)

MVA Membership (with division affiliation, indicate your division below) .....	\$15.00	
Paraprofessional .....	\$4.00	
Retiree .....	\$1.00	
Student .....	\$2.00	
Associate .....	\$20.00	
MVA Membership (direct with no division affiliation) .....	\$20.00	

### DIVISION MEMBERSHIP

*(Take this opportunity to join your affiliated organization. Check divisions you wish to join)*

<b>Administrators</b>	
MCVA .....	\$3.00
MCVA/NCLA .....	\$23.00
<b>Agriculture</b>	
MATA .....	\$125.00
NVATA .....	\$35.00
Agriculture Educator Magazine .....	\$7.00
Business Education (MBEA) .....	\$10.00
Cooperative Education (MACE) .....	\$5.00
Health Occupations (HOE) .....	\$4.00
Home Economics (HEAM) .....	\$3.00
Marketing Education (MMEA) .....	\$45.00
<b>Special Needs (MAVESNP)</b>	
Professional .....	\$5.00
Paraprofessional .....	\$5.00
Full-time Student .....	\$3.00
Trades and Industry .....	\$5.00
T&I Subject Taught .....	
<b>New and Related Services: MVA Sections - under 25 members</b> .....	
Community College Personnel	Maryland Personnel
Employment & training	MD Council of Vocational Teacher
Equity Specialists	Educators (MCVTE)
Independent Schools	Project Independents
Industrial Arts (MIAD)	Vocational Counselors (MVCA)

**TOTAL:** \_\_\_\_\_

If it's Technology Education,  
it's MODERN!

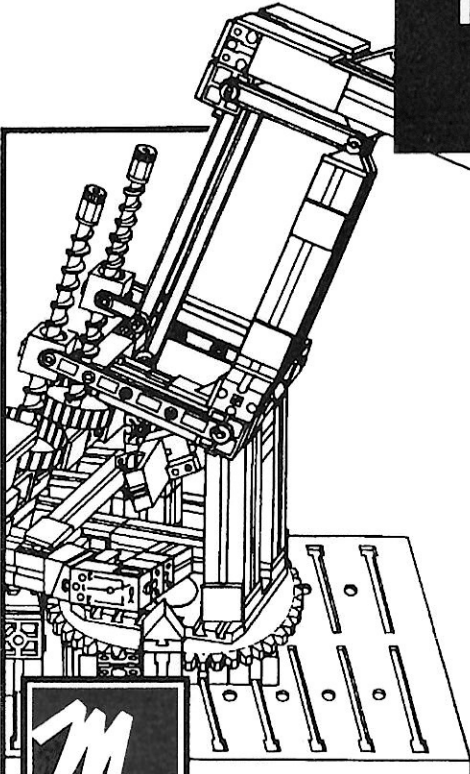

MODERN  
has been  
serving

education since 1953. As curricula have evolved from industrial arts to technology education, we've changed too. We offer a complete selection of products with modular competency based curriculum for technology education - CAD, robotics, transportation, communication, pneumatics, plastics, electronics, hydraulics, CNC equipment, plus lab furniture and more. If you're teaching technology, we have products for you.

Call 800-243-2329 for your FREE Technology Education Catalog.



MODERN SCHOOL SUPPLIES, INC.  
PO Box 958  
Hartford, CT 06143  
800-243-2329

### *The Current*

Dr. Brian K. McAlister  
3216 J.M. Patterson Building  
University of Maryland  
College Park, Maryland 20742-2211

NON-PROFIT  
U.S. POSTAGE  
**PAID**  
PERMIT NO. 775  
BALTIMORE, MD